

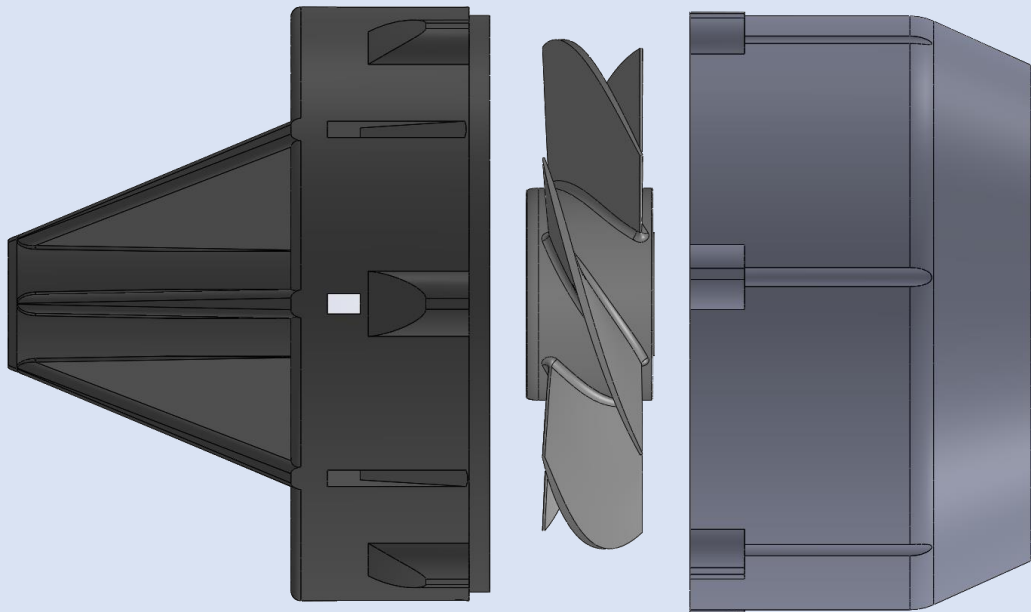

RAIDER SAFETY JET P/N RO-SJA-50HP OWNER'S MANUAL



RAIDER OUTBOARDS, INC.
1855 SHEPARD DRIVE,
TITUSVILLE, FL 32780
TELEPHONE: (321) 383-9585

RAIDER Outboards

MULTI-FUEL SUBMERSIBLE ELECTRIC START OUTBOARD ENGINES

The Raider series of outboard motors are dedicated to the Marine Raiders established by the United States Marine Corps during WW II and are said by many to be the first United States special operations force. Handpicked from the elite, these men were given specialized training and the best equipment. They distinguished themselves during the conduct of clandestine amphibious landings, utilizing small inflatable boats, operating behind enemy lines in direct support of combat operations in the Central Pacific and Solomon Islands. Even though the Raiders were disbanded at the close of WW II the need for specially trained warfighters and the requirements for specialized equipment did not. Today's Special Operations Forces (SOF) under the United States Special Operation Command (USSOCOM) are expected to conduct similar and far more demanding missions, to that end and with those warfighters in mind the Raider OBM is specifically developed for SOF that routinely operate within the often unforgiving, highly demanding, dynamic maritime environment.

WHO WE ARE

- Raider Outboards, Inc. is a-US owned and operated company based in Central Florida near Kennedy Space Center, located in the Space Port Commerce Park. We design and produce multi-fuel, submersible, lightweight outboard motors and associated parts that include a Safety Jet; transom plates; carts and transportation cages. Our markets include Department of Defense (DOD), Other Government Agencies (OGA), National and Local Law Enforcements and First Responder Services, Search & Rescue and commercial/retail.
- The Raider, patent pending, Safety Jet can be purchased in a kit which retrofits a propeller drive to a jet pump system. The Safety Jet was designed to improve safety for swimmers and divers in both real-world and training situations. The Safety Jet is excellent for "brown" water operations where search and rescue operations routinely happen in which higher probabilities of striking submerged objects exist. For coastal or beaching operations in unfamiliar waters it provides additional protection from rocks or coral easily absorbing hits that could ruin propellers when moving to and from a beach landing site.
- Raider also provides a series of transom plates that are attached to the transom of the CRRC. The transom plates have single and dual motors configurations. The transom plates provide centerline alignment and safety if the motor clamps loosen under vibration. Specialty items like extended handles, extended fuel hose connections, outboard motors carts and transportation cages are also available.

WHAT WE ARE ABOUT

Raider develops, manufactures, and provides technical support services for highly reliable outboard motors for today's warfighter. Our designs are field proven, add capacity and capability to perform the most difficult and demanding maritime missions. Features include;

- Simple and Robust.
- System Redundancy.
- Minimized Electronics.
- Air droppable.
- Bagless submersion.
- Superior dewatering.
- Leader in horsepower to weight ratio.
- 25% better fuel efficiency than any other motor in its class.
- Easy to maintain and troubleshoot.

OUR MISSION

Raider Outboards will provide and deliver the most reliable premium products, hands on training, highest quality to the customer and serve as the premier outboard motor company to the U.S. Military; while honoring those who protect, defend, and support our communities and our country.



Chris Woodruff
Director of Engineering
Raider Outboards Inc.
Chris@raideroutboards.com
321-567-2309

A handwritten signature in black ink that reads "Chris Woodruff". The signature is written in a cursive, flowing style.

CONTENTS

INTRODUCTION TO THE SAFETY JET.....	1
SAFETY JET SPECIFICATIONS	2
LIMITED WARRANTY	3
GENERAL SAFETY PRECAUTIONS	4
SERVICING, REPLACEMENT PARTS & LUBRICANTS	6
MAINTENANCE.....	6
ASSEMBLY OVERVIEW	8
SAFETY JET PARTS IDENTIFICATION AND DESCRIPTION	9
INSTALLATION INSTRUCTIONS.....	11
PERFORMANCE CONSIDERATIONS	19
TROUBLESHOOTING	20
SAFETY JET ASSEMBLY PARTS LIST.....	21
TOOLS REQUIRED	22

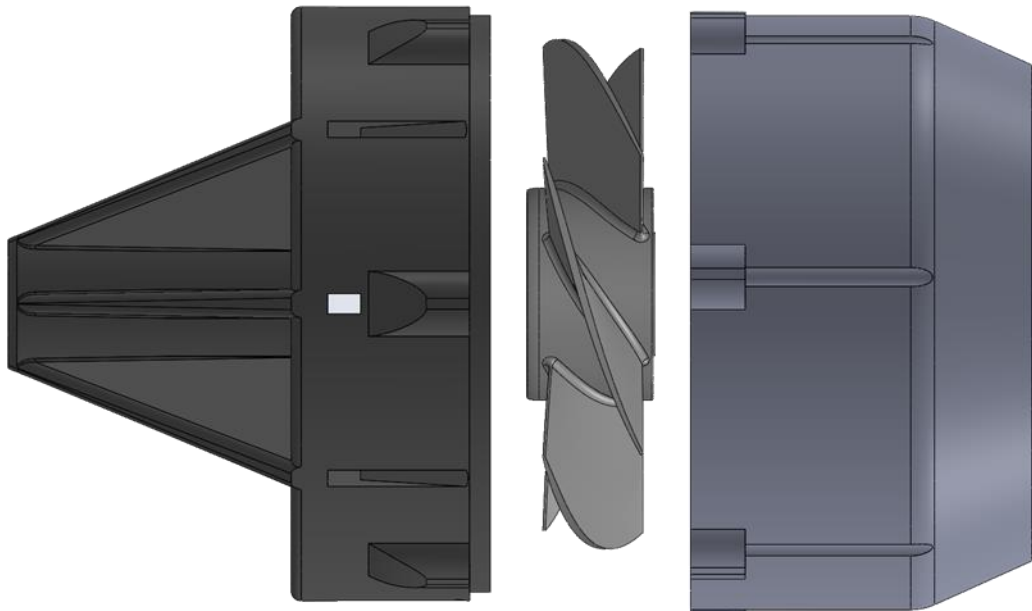

INTRODUCTION TO THE SAFETY JET

The Safety Jet was designed to improve safety for swimmers and divers in both real-world and training situations, it prevents injury to personnel from inadvertent contact with the propeller. The Safety Jet is excellent for “brown” water operations where search and rescue operations routinely happen in which higher probabilities of striking submerged objects exist. For coastal or beaching operations in unfamiliar waters and often conduct at night, it provides additional protection from rocks or coral easily absorbing hits that would ruin propellers when moving to and from a beach landing site rendering a craft dead in the water. This bolt on component installs in mere minutes should the mission or situation dictate. Protects crafts propulsion systems when transiting through shallow and flooded areas from unseen obstructions. Moreover, provides increased reliability during beaching or Search and Rescue applications that adds capability and capacity to any maritime mission set.

a. Specific Features Include.

- Exhaust Ports (360°) that aid in preventing cavitation by keeping exhaust gasses out of the impeller, reducing drag and performances losses.

- Stainless Steel Impeller, impact resistant, adds strength and performance for critical shallow water or beaching operations where the likelihood of contact with biomatter or underwater obstructions is greatly increased.

- Extended Tines over Lower Unit. Protect the gear case from damage by deflecting debris away from the Safety Jet intake. Greatly decreasing the probability of biomatter or a foreign object entering the Impeller Housing.



- The Raider Safety Jet is a specially manufactured outboard motor jet pump for use on the Raider 50 HP outboard motor. However, the Raider Safety Jet is also compatible with other outboards including Mercury and Nissan.
- b. Successful usage can only be assured on condition that this manual is read through in its entirety and the maintenance routines described in this manual are followed. Should difficulty arise with the Raider Safety Jet, please follow the troubleshooting procedures listed at the end of this manual. For any issues, contact Raider Technical Support via email or Phone.
 - TechSupport@raideroutboards.com
 - 321-567-2306

SERIAL NUMBER LOCATION

- a. This Raider Safety Jet has been delivered with documentation which contains the Individual Serial Number.
- b. The Serial Number is located on the inside of the Stator.



- c. Record the Serial Number of your Safety Jet Assembly [_____]

SAFETY JET SPECIFICATIONS

ITEM	RO-SJ-40
Overall length	15 inches (cone)
Overall width	9 inches
Overall height	9 inches
Weight	15 lbs.
Transom length	Long or Short Shaft
Exhaust System	Through Hub Side Exhaust
Cooling System	Water
Lubrication system	Water
Lower Unit Spline	12
Trim Angle	Maintain to surface to water

LIMITED WARRANTY

- a. Unboxing. Visually inspect each component, ensure that all physical aspects of the Raider Safety Jet are free of damage. All parts and part numbers are detailed within this manual to include pictures.
- b. Raider Safety Jet is fully guaranteed against defective materials and workmanship for the period from the date of purchase for one year. The limited warranty will not apply to the normal wear and tear of parts, adjustments, tune-ups, maintenance items or damage caused by:
 - Damage caused due to collisions, contact with foreign objects, both in and out of water.
 - Damage caused due to marine growth on Safety Jet surfaces.
 - Damage caused due to operator neglect, lack of or the conduct of improper maintenance procedures.
 - Damaged caused due to use of other than Raider Safety Jet authorized parts.
 - Damaged caused due to improper Safety Jet installation.
- c. For warranty related issues, please contact Raider Technical Support via email or Phone.
 - TechSupport@raideroutboards.com
 - 321-567-2306



GENERAL SAFETY PRECAUTIONS

- a. Prior to the installation of the Safety Jet follow the following precautions, remove the Lock Plate from the Engine Stop Switch and disconnect the Start Battery. This will prevent the motor from starting or turning over in the event of contact with the Start Button.
- b. When installing the Safety Jet ensure that the procedures are readily availed and properly followed and use the proper tools to prevent personal injury; product or property damage.
- c. As the operator/driver of the boat with Safety Jet, you are responsible for the safety of those aboard and those in other crafts around yours. Therefore, you should possess thorough knowledge of correct operation of the boat and the Safety Jet. To learn about the correct operation and maintenance of the Safety Jet, please read through this manual carefully. Instruct people that could come in contact with the Safety Jet to make a fist. The hand cannot come in contact with the Safety Jet impeller if this is done.
- d. It is very difficult for a swimmer floating in the water to take evasive action should he or she see a power boat with Safety Jet heading in his/her direction, even at a slow speed. Therefore, when your boat is in the immediate vicinity of people in the water to be picked up care should be used. The Safety Jet option (jet pump) is especially useful for swimmer pickup and training purposes.
- e. Boats are rated and certified in terms of their maximum horsepower and weight of outboard, and this is shown on the boat's certification plate. Do not equip your boat/RIB with an outboard that exceeds this limit. The Safety Jet will add weight to the outboard motor.
- f. Do not operate the engine until it has been securely mounted on the motor in accordance with the instructions.
- g. Serious injury is likely if a person in the water makes contact with a moving boat, safety jet housing or any solid device rigidly attached to a boat.
- h. Any people that could possibly come in contact with the Safety Jet should be directed to make a fist that will protect any part of the body from being injured by the internals of the Safety Jet.

NOTICE: DANGER/WARNING/CAUTION/NOTE

- a. Before installing, operating or otherwise handling your Raider Safety Jet, be sure to thoroughly read and understand this operations section of this manual and carefully follow all of the instructions. Of particular importance is information preceded by the words "**DANGER**," "**WARNING**," "**CAUTION**," and "**Note**." Always pay special attention to such information to ensure safe operation of the outboard motor at all times.
- b. The following safety statements are found throughout this manual and indicate information which, if ignored, could result in fatal safety hazards or property damage.



Failure to observe will result in severe personal injury or death, and possibly property damage.



Failure to observe could result in severe personal injury or death, or property damage.



Failure to observe could result in personal injury or property damage.



This instruction provides special information to facilitate the use or maintenance of the Safety Jet with the outboard motor or to clarify important points.

SERVICING, REPLACEMENT PARTS & LUBRICANTS

The Safety Jet requires only a minimal amount of servicing. Any Safety Jet part can be ordered independently. No lubricants are required during operation as water acts as the lubricant. Servicing is required if cracks appear or unusual noises are noted or craft performance is noticeably different.



Ensure during Safety Jet assembly that all bolts are adequately greased with marine grease, NLGI #2 certified marine grease is strongly recommended.

MAINTENANCE

The Safety Jet is a vital component and will be subjected to air drops; submersion and other abuse typical outboards never receive. As a result, maintenance actions become even more critical to ensure mission success and safety for all aboard your craft. The most crucial maintenance actions are the Pre and Post Operations Checks. The list below contains the recommended maintenance actions, this list of preoperational checks is not inclusive and may be modified to meet operational commitments. Not all steps may be required every time prior to start.

Condition	Maintenance Action
Unboxing	<ul style="list-style-type: none"> • Inventory components. • Visually inspect each part for damage. • Record Serial Number of Safety Jet Assembly in space provided in this Manual
Installation	<ul style="list-style-type: none"> • Apply marine grease to part surfaces for corrosion protection and to prevent seizing. NLGI #2 certified marine grease is strongly recommended.
Pre-Operations Checks	<ul style="list-style-type: none"> • Inspect and verify impeller is true and free of nicks, chips, and other damage that could affect performance. • Inspect the thrust washer and mounting hardware for damage. • Inspect all parts for oxidation/corrosion and remove with a wire brush. • Reapply marine grease where applicable. • Check Captive Screws for tightness. • Inspect the Zinc Anode and replace if reduced in size by 50 percent.
Post Operations Checks	<ul style="list-style-type: none"> • Inspect and verify impeller is true and free of nicks, chips, and other damage that could affect performance. • Inspect the thrust washer and mounting hardware for damage. • Fresh water wash both exterior and interior of the Safety Jet. Raider recommends incorporating "Salt-A-Way" as a part of your post operations maintenance actions

	<ul style="list-style-type: none"> • Motor should be run for a minimum of 5 minutes on fresh water after every operational period, 10 minutes after a submersion period.
<p>After Beaching or contact with underwater Obstruction</p>	<ul style="list-style-type: none"> • Inspect and verify impeller is true and free of nicks, chips, and other damage that could affect performance. • Inspect the thrust washer and mounting hardware for damage. • Inspect Bearing Cap and Gear Case mating surfaces for oil leaks. • Inspect the Skeg and verify free of damage.
<p>50 Hours or Every 3 Months</p>	<ul style="list-style-type: none"> • Disassemble Safety Jet Assembly. • Visually inspect each part for damage. • Inspect all parts for oxidation/corrosion and remove with a wire brush. • Reapply marine grease on all component surfaces including Propeller Shaft. • Inspect the Zinc Anode and replace if reduced in size by 50 percent. • Reassemble Safety Jet. • Function test the Safety Jet in Forward, Neutral, and Reverse



ASSEMBLY OVERVIEW

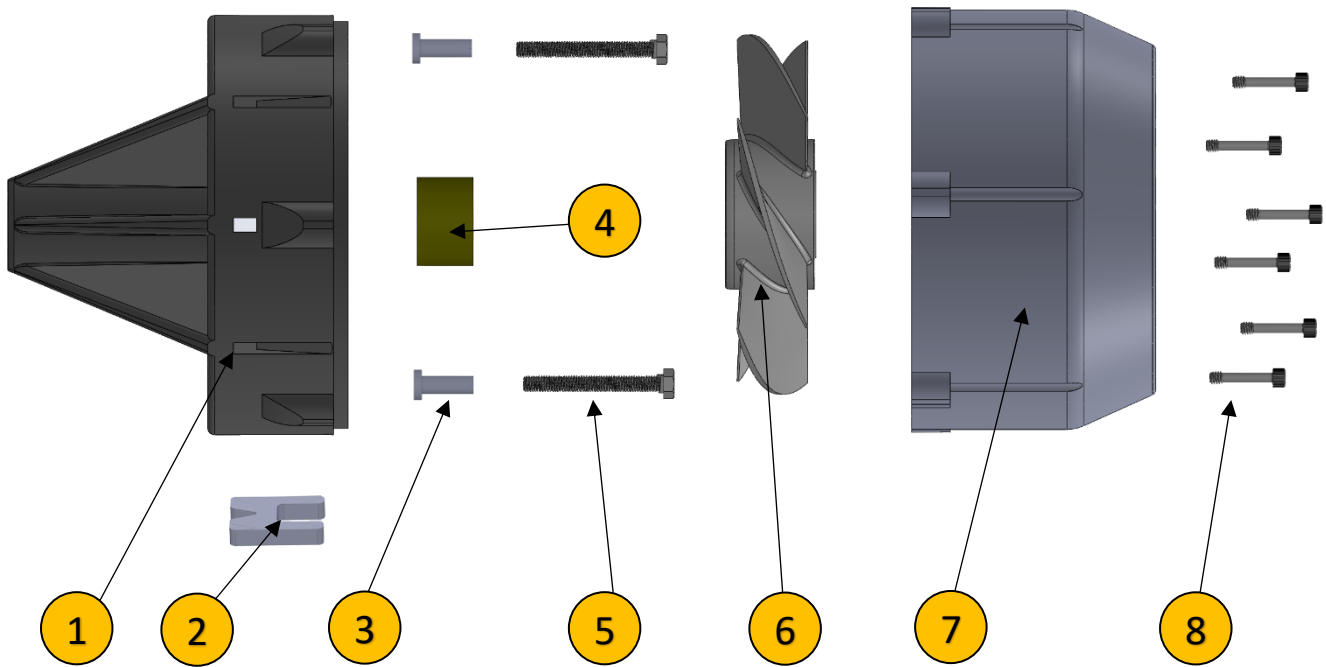











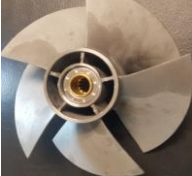

ITEM/Part Number	Description
1.	Stator
2.	V-Block
3.	Stator Bolt Inserts Qty (2)
4.	Impeller Spacer
5.	Bolts Qty (2)
6.	Impeller
7.	Nozzle
8.	Nozzle Captive Screws Qty (6)



Ensure during Safety Jet assembly that all bolts are adequately greased with general purpose marine grease.

SAFETY JET PARTS IDENTIFICATION AND DESCRIPTION

Item/Component	Description/Remarks	
Brass Impeller Spacer (Provided with Safety Jet Kit)	Ensures that the Stator remains aligned with Propeller Shaft be evenly distributing the axial force generated by the rotating Propeller Shaft.	
Captive Screws with Hi Collar Lock Washer (Provided with Safety Jet Kit)	Qty (6) - 1/4" X 20 X 1" - 3/16" Allen cap head screws coupled with Qty (6) Hi Collar Lock Washers. Used to secure the Nozzle to the Stator.	
Castle Nut (Reuse part in place)	A slotted nut that has slots cut into one end of the nut, threaded pas the pre drilled hole on the end of the propeller shaft. Secure with the split pin preventing vibration from or motion from undoing the nut.	
Impeller (Provided with Safety Jet Kit)	Stainless steel 5 blade impeller that moves water through the Safety Jet. The impeller is very sharp on the leading edge - use caution when handling. The impeller "flat" side is installed onto the shaft first with the boss side up.	
Modified Zinc Anode (Provided with Safety Jet Kit)	Replace the existing Zinc Anode/Trim Tab with a lower profile anode that fits above the Stator in the existing mount.	
Safety Jet Nozzle (Provided with Safety Jet Kit)	Produces the thrust and maintains a barrier between the spinning impeller. A series of fixed internal fins are located inside the nozzle to counter the rotation of the water coming off of the impeller.	
Split Pin (Reuse part in place)	A stainless-steel is cotter key (split pin) 7/64 x 1 inch long. Provided and used to prevent the Castle Nut from loosening. (M2x32 ISO 1234 A2 S/S)	
Stainless Steel Washer (Provided with Safety Jet Kit)	5/8 Flat Washer, replaces the Flat Washer in the propeller Stack Assembly.	

<p>Stator (Provided with Safety Jet Kit)</p>	<p>Bolts on the lower unit and has six extended tines to deter debris from entering the Safety Jet. Transfers exhaust gasses from rear to side outlets. Constructed of aluminum for strength.</p>	
<p>Stator Bolt Inserts (Provided with Safety Jet Kit)</p>	<p>Qty (2), used to align the Stator Bolts to the mounting holes in the Bearing Cap through the Stator.</p>	
<p>Stator Bolts (Provided with Safety Jet Kit)</p>	<p>Qty (2) stainless steel bolts 8mm x 1.25 x 70mm. (10mm heads). Secures the Stator to the Lower Unit. Retain the original bolts with the propeller assembly for reinstallation when required.</p>	
<p>Thrust Washer (Reuse part in place)</p>	<p>Transfers the load of the impeller into forward thrust.</p>	
<p>V-Block (Provided with Safety Jet Kit)</p>	<p>Works in tandem with the Impeller Spacer Distributing torque generated by axial forces away from Stator to the Lower Unit.</p>	

INSTALLATION INSTRUCTIONS

- a. This section of the owner's manual provides the instructions for the proper installation and service of the Raider Safety Jet to your outboard motor. Improper installation or servicing of this Raider product could result in damage to the Safety Jet, outboard motor or personal injury to those installing or operating the product.
- b. Installation will not require the use of special OEM mounting hardware when assembling the Safety Jet. Use only hardware provided by Raider or your outboard motor OEM. Anodic rim tab or anodic plate on your existing motor can be left intact. There should not be a clearance issue between the anodic trim plate and Safety Jet.



Prior to the installation of the Safety Jet remove the Lock Plate from the Engine Stop Switch and disconnect the Start Battery. This will prevent the motor from starting or turning over in the event of contact with the Start Button.



Performing service or maintenance without first disconnecting the battery can cause product damage, personal injury, or death due to fire, explosion, electrical shock, or unexpected engine starting. Always disconnect the battery cables from the battery before maintaining, servicing, installing, or removing Safety Jet components.



After completing installation, place these instructions, propeller and bolts in a secure place for future use in the event you want to reinstall to the propeller.

STEP 1. REMOVE THE PROPELLER FROM THE LOWER UNIT (GEAR CASE) OF THE OUTBOARD MOTOR.

- a. Remove the Zinc Anode from below the Anti-Cavitation Plate. Use a 10mm Socket to loosen and remove one bolt, washer anode. Retain the bolt and washer for the Safety Jet Install. The anode will be retained for reinstall if the requirement to use the propeller exists. **(Img. 1a)**
- b. Remove the Split Pin. Use a pair of needle nose pliers to straighten out the bent ends of the Split Pin. Using a Flat head Screwdriver hold firm against the split end on the pin with your thumb and fore finger push the pin through the propeller shaft exposing the head enough to be gripped by the needle nose pliers. Slide the Split Pin free. The Spilt Pin will need to be retained for Safety Jet Installation, or maybe need to be discarded if it cannot be reused. **(Img. 1b)**
- c. Remove the Castle Nut. Use a 22mm Socket to remove the Castle Nut. Place a block of wood or other material between the base and the Anti-Cavitation Plate to prevent the propeller from turning while the Castle Nut is removed. The Castle Nut will need to be retained for the Safety Jet Installation. **(Img. 1c)**
- d. Remove the Stainless-Steel Washer and Stopper from the propeller shaft. Using the Flat Head Screw driver, gentle pry the washer and stopper lose and remove them from the propeller shaft. Retain both components for reinstall if the requirement to use the propeller exists. **(Img. 1d)**
- e. Remove propeller, retained in a secure location for reassemble should the use of a propeller be required.
- f. Remove Thrust Washer. The Thrust Washer and retain for Safety Jet Installation. **(Img. 1f)**
- g. Remove (2) factory 10 mm hex bolts from bearing cap. Using a 10 mm Socket loosen and remove the upper and lower bolts from the bearing cap. These hex bolts are shorter than those required to install the Safety Jet. Retain these bolts in a secure location for reassemble. **(Img. 1g)**

**Img 1a.** Remove Zinc Anode with 10 mm Socket**Img 1b.** Remove Split Pin with needle nose pliers



Img 1c. Remove Split Pin with needle nose pliers



Img 1d. Remove the Stainless-Steel Washer and Stopper from the propeller shaft



Img 1f. Remove Thrust Washer



Img 1g. Remove (2) factory 10 mm hex bolts from bearing cap



Img 1h. Split Pin, Thrust Washer, Castle Nut, and the 10mm bolt and wash all required to Install Safety Jet



Img 1i. Removed parts required for keep reinstallation of the propeller when required.

STEP 2 PREPARE THE PROPELLER SHAFT AND COMPONENTS

- a. Prior to installation of the Safety Jet, perform an inspection of the Lower Unit (Gear Case) and Propeller Shaft. Examine closely the mating surface for the Propeller Shaft Assembly and the Lower Unit. Ensure that there is no indication of a defective oil seal. **(Img 2a.)**
- b. Closely examine/inspect the propeller shaft, for corrosion, pitting, and straightness. Clean the propeller shaft with a shop towel and remove any dirt, debris, and old grease and reapply a fresh coat of grease. **(Img 2b.)**
- c. Clean components that were removed in Step 1 that will be utilized for the installation of the Safety Jet. These components should consist of the Split Pin, Thrust Washer, Castle Nut, and the 10 mm Bolt and washer used to secure the Zinc Anode. **(Img 2c.)**
- d. Ensure parts that are not being utilized are stowed in a safe secure place should the requirement to use the propeller develop.
- e. Inventory and stage all the Safety Jet Components for installation. **(Img 2e.)**

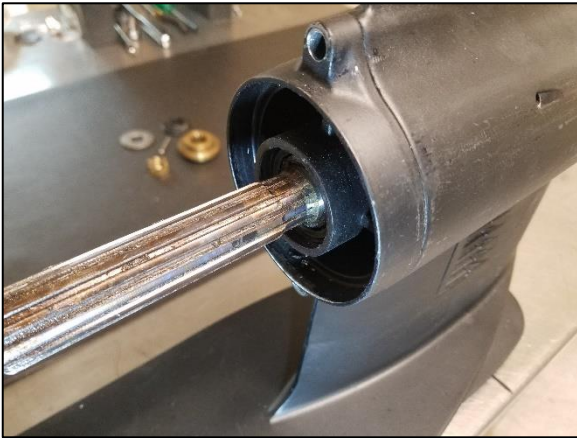

Img 2a. Inspect of the Lower Unit and Propeller Shaft.



Img 2b. Inspect the propeller shaft, for corrosion, pitting, and straightness



Img 2c. Clean components for reuse



Img 2e. Safety Jet staged for installation

STEP 3 STATOR INSTALLATION.

- a. Install the Thrust Washer onto the propeller shaft as shown in image 3a (**Img 3a**). Ensure that a liberal coat of marine grease is applied to the washer.
- b. Lay the Stator face down on a horizontal surface. Take 2(two) Stator Bolt Inserts and place one in each hole of the stator Bosses inboard toward shaft as shown in image 3b (**Img 3b**). A slight dab of marine grease will hold the inserts in place when positioning the Stator onto the Lower Unit.
- c. Guide the Stator over the propeller shaft and align with the upper and lower bearing cap bolt holes leaving about a 2-inch gap between the Stator and Bearing Cap. Insert the V-Block between the upper exhaust arm of the Stator and the Lower Unit. Guide the Stator against the Bearing Cap until flush ensuring the V-Block remains secure in place. (**Img 3c**)
- d. Insert the two (2) 8 mm x 1.25 x 70mm with 10 mm hex head bolts with Bellville washer and tighten finger tight. (**Img 4c**)



Img 3a. Install the Thrust Washer onto the propeller shaft

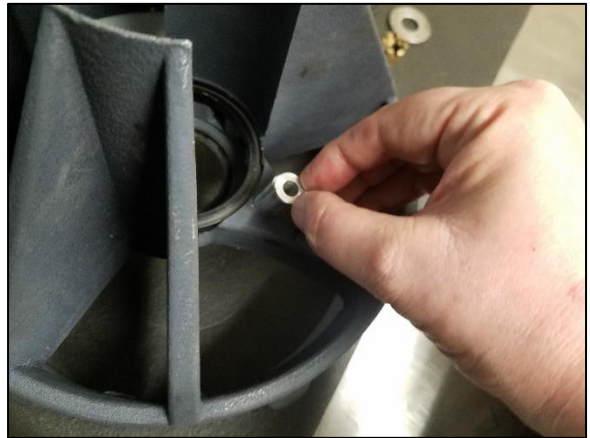

Img 3b. Install the Stator Bolt Inserts x 2(two) Bosses inward towards Propeller Shaft



Img 3c. Insert the V-Block between the upper exhaust arm of the Stator and the Lower Unit



Img 4d. Insert the two (2) Bolts with Nord-lock wedge washer and tighten finger tight

STEP 4. SPACER INSTALLATION

- a. Guide the Brass Impeller Spacer over the propeller shaft. Coat with general purpose Marine Grease. Using your thumbs apply pressure to the spacer and push it into place inside the Stator as shown Images a1 and a2. **(Img 4a1/4a2)**



Img 4a1. Apply pressure and push it into place inside the Stator



Img 4a2. Brass Impeller Space in place flush with Stator surface.

- b. Tighten the upper and lower bolts evenly with Nord-Lock Wedge Washer. Using a torque wrench with a 10 mm Socket, tighten each mounting bolt to 10 ft/lbs. **(Img 4b)**



Img 4b. Torque wrench set to 10ft.lbs



Improper alignment could result in damaged equipment.

STEP 5 INSTALL IMPELLER AND STACK SEQUENCE ASSEMBLY

- a. Install Stainless Steel Impeller. Ensure the Boss side up, using care in avoid the sharp blades, slide the Impeller over the Propeller shaft until it seats against the Brass Impeller Spacer. **(Img 5a)**
- b. Install the Stainless-Steel Washer and Castle Nut. Slide the provided 5/8 Inch Stainless Steele Washer over the propeller shaft followed by the Castle Nut and tighten by hand. **(Img 5b)**
- c. Tighten the Castle Nut. With a 22 mm socket tighten the Castle Nut on the Propeller Shaft. Wedge a wood board in place to prevent the impeller movement to allow for tightening. The Castle Nut should be tightened to the point to allow for the insertion of the Split Pin/Cooter Key. **(Img 5c)**
- d. Insert the split pin through the Castle Nut. With the needle nose pliers, bend each end into to an angle that would prevent the Split Pin from falling out. **(Img 5d)**

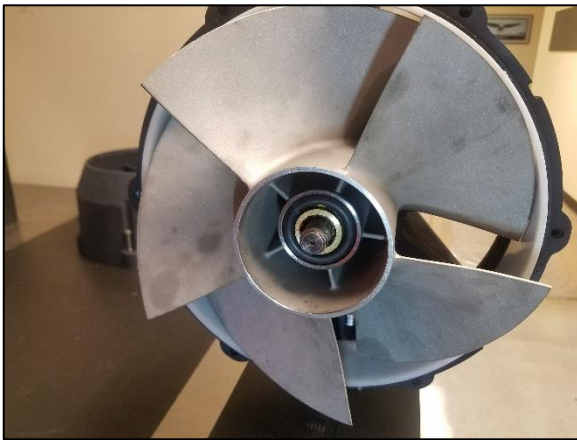

Img 5a. Bass Impeller Space in place flush with Stator surface.



Img 5b. Install the SS Washer and Castle Nut.



Img 5c. With a 22 mm socket tighten the Castle Nut on the Propeller Shaft



Img 5d. Insert the split pin through the Castle Nut

STEP 6 NOZZLE INSTALLATION.

- a. Install modified Zinc Anode. Take the wafer anode provided with the Safety Jet and insert it into the anode slot on the underside of the Anti-Cavitation Plate. Using the 10 mm hex bolt and washer from part 1, align with mounting hole and hand tighten bolt. With a 10 mm Socket firmly tighten the bolt. **(Img 6a)**
- b. Prior to placing the Nozzle into place, insert all six (6) of the Captive Screws with High Collar Lock Washers into their respective mounting holes. **(Img 6b)**
- c. With both hands securely grasp the Nozzle and align with the six mounting holes of the Stator. Push the Nozzle firmly into place. Maintain pressure with the off-hand and with the provided 3/16" Allen T-Handle Wrench securely tighten each Captive Screw. **(Img 6c/6d)**



Img 6a. Install the modified Zinc Anode on Anti-Cavitation Plate



Img 6b. Insert all six (6) of the Captive Screws with High Collar Lock Washers into their



Img 6c. Securely grasp the Nozzle and align with the six mounting holes of the Stator



Img 6d. Maintain pressure with the off-hand and with securely tighten each Captive Screw

PERFORMANCE CONSIDERATIONS

- a. An Outboard Motor with the Safety Jet installed does perform similar to an Outboard Motor with a propeller. There are some notable differences in the steering and boat operation, depending upon the craft installed. The Safety Jet turns at a much tighter radius than a propeller with no cavitation. The craft will typically plane out quicker; however, there is an approximately 10% loss on top end speed. Of course, trim angle, craft proper inflation, weight distribution, prevailing environmental conditions and Operator experience level also will directly contribute to craft performance. To ensure maximum performance of the Outboard Motor with the Safety Jet installed all areas should be considered to improve performance.
- b. The Safety Jet was developed in part to improve safety during operations and training. The Safety Jet coupled with strict adherence to organizational safety procedures will eliminates the prospect of personnel being injured by a rotating propeller. Although highly unlikely and extremely difficult it is not impossible to insert hands into the Safety Jet front or back; even though protection is provided. It is important young children not stick their hands into these chambers. When in the water near a Safety Jet the Operator should place the motor into neutral if possible. Stay away from the stern of the craft. Recover swimmers on the bow. Should inadvertent contact happen with the Safety Jet in operation, clench hands into fists and cross arms over your head to minimize impact.

TROUBLESHOOTING

Symptom	Corrective Action
Craft will not plane	<ul style="list-style-type: none"> • Change the Trim Angle of the Motor by moving/changing the Thrust Rod position. • Check for proper craft inflation. • Adjust craft load distribution. • Check fuel supply.
Noise in Safety Jet	<ul style="list-style-type: none"> • Remove motor from water. • Inspect pump for foreign objects. • Inspect Captive Screws for tightness. • Inspect V-Block installation ensure component is properly installed. • Remove, Impeller check Stator Bolt Torque Settings.
Knock in Lower Unit at idle speeds	<ul style="list-style-type: none"> • This is normal and caused by the shifter spring movement against Propeller Shaft Assembly.
Cavitation	<ul style="list-style-type: none"> • Reduce Speed and secure motor. • Change the Trim Angle of the Motor by moving/changing the Thrust Rod position. • Tilt the motor up and check for damage to the Safety Jet. • Check V-Block position. • Check for bio matter, or debris caught in the stator. • Clear debris, resume operations.

SAFETY JET ASSEMBLY PARTS LIST

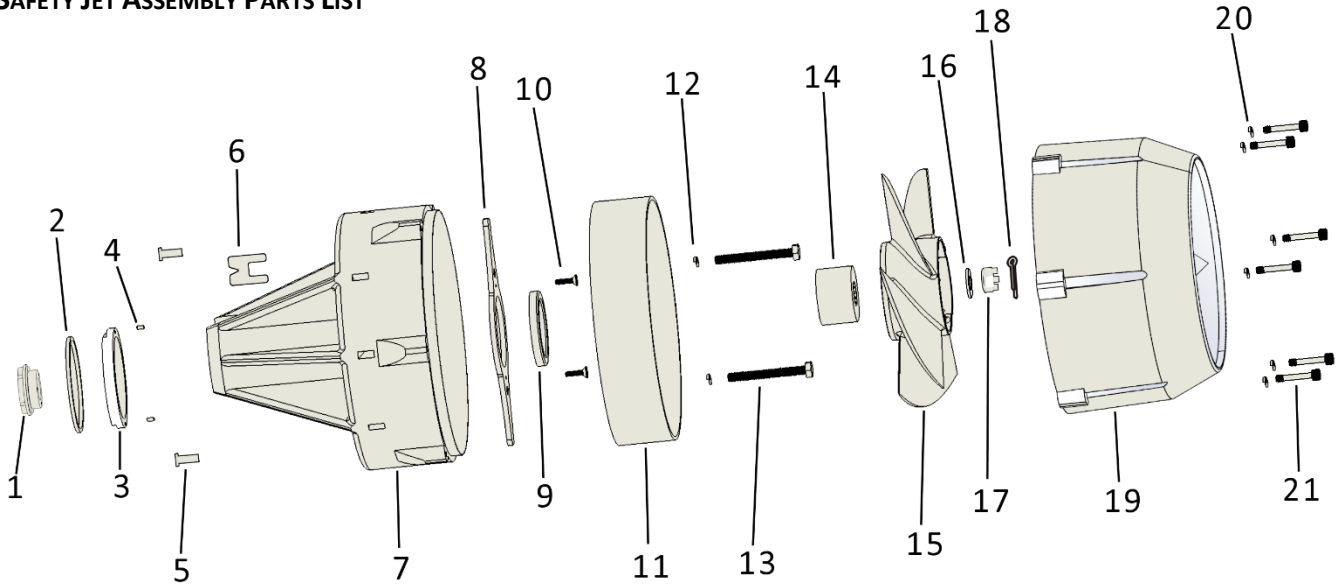

Ref No.	Part No.	Description	Q'ty	Remarks
1	RO-SJ-50-010	Thrust Washer	1	3C8-64231-0
2	RO-SJU-020	O-Ring	1	
3	RO-SJU-030	Aluminum Alignment Ring	1	
4	RO-SJU-040	SS Dowel Pin	2	1/8x1/4 SS DPS02X04MC
5	RO-SJ-50-050	Stator Bolt Inserts	2	
6	RO-SJU-060	V-Block	1	
7	RO-SJU-070	Stator	1	
8	RO-SJU-080	Exhaust Cap	1	
9	RO-SJU-090	Stator Exhaust Seal	1	
10	RO-SJU-100	Aluminum Screws	2	3/8 x 10/32
11	RO-SJU-110	Wear Ring	1	UHMW
12	RO-SJ-50-120	SS Nord-Lock Wedge Lock Washer	2	1/4" 88125554
13	RO-SJ-50-130	SS Stator Bolts	2	M6X65 933 A2
14	RO-SJU-140	Brass Impeller Spacer	1	
15	RO-SJU-150	SS Impeller	1	
16	RO-SJU-160	SS Washer	1	5/8"
17	RO-SJU-170	Castle Nut (Propeller Nut)	1	353-64121-0
18	RO-SJU-180	Split Pin (Cotter Key)	1	951503-0325
19	RO-SJU-190	Nozzle	1	
20	RO-SJU-200	SS Hi Collar Lock Washer	6	1/4" 18-8ss
21	RO-SJU-210	Captive Screw	6	1/4-20x1 1/2 114121-1 .250-SS

RAIDER Outboards, Inc.
1855 Shepard Drive
Titusville, FL 32780

www.raideroutboards.com

Telephone: (321) 383-9585

RO-SJA-50HP
SAFETY JET

Propeller to Pump Jet